

## QUICK GUIDE

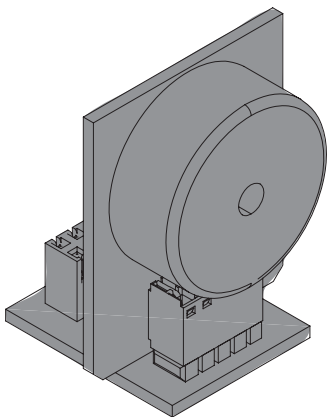

**DAB**<sup>®</sup>  
WATER • TECHNOLOGY

Ed.09/14 - 60166479

